

# HAE75W SERIES

HALF-BRICK DC-DC CONVERTER

4:1 ULTRA WIDE INPUT RANGE  
UP TO 75Watts



## FEATURES

- NO MINIMUM LOAD REQUIRED
- 3000VAC REINFORCED INSULATION FOR 110VIN  
2250VDC BASIC INSULATION FOR 24VIN AND 48VIN
- UL60950-1, EN60950-1, & IEC60950-1 SAFETY APPROVALS
- COMPLIANCE TO EN50155 AND EN45545-2 RAILWAY STANDARD
- CE MARKED
- COMPLIANT TO RoHS II & REACH

## APPLICATIONS

- RAILWAY SYSTEM
- WIRELESS NETWORK
- TELECOM/DATACOM
- INDUSTRY CONTROL SYSTEM
- DISTRIBUTED POWER ARCHITECTURES
- SEMICONDUCTOR EQUIPMENT

3000VAC ISOLATION	2250VDC ISOLATION	REMOTE CONTROL	UVP	OCP	SCP	OVP	OTP
-------------------	-------------------	----------------	-----	-----	-----	-----	-----

## TECHNICAL SPECIFICATION

All specifications are typical at nominal input, full load and 25°C otherwise noted

Model Number	Input Range	Output Voltage	Output Current @Full Load	Input Current @ No Load	Efficiency	Maximum Capacitor Load
	VDC	VDC	A	mA	%	µF
HAE75-24S3P3W	9 ~ 36	3.3	20	85	87	60600
HAE75-24S05W	9 ~ 36	5	15	120	88	30000
HAE75-24S12W	9 ~ 36	12	6.3	185	88	5250
HAE75-24S15W	9 ~ 36	15	5	185	88	3330
HAE75-24S24W	9 ~ 36	24	3.2	85	87	1330
HAE75-24S28W	9 ~ 36	28	2.7	85	87	960
HAE75-24S48W	9 ~ 36	48	1.6	85	87	330
HAE75-48S3P3W	18 ~ 75	3.3	20	60	88	60600
HAE75-48S05W	18 ~ 75	5	15	60	90	30000
HAE75-48S12W	18 ~ 75	12	6.3	90	90	5250
HAE75-48S15W	18 ~ 75	15	5	50	89	3330
HAE75-48S24W	18 ~ 75	24	3.2	50	88	1330
HAE75-48S28W	18 ~ 75	28	2.7	50	88	960
HAE75-48S48W	18 ~ 75	48	1.6	50	87	330
HAE75-110S3P3W	43 ~ 160	3.3	20	10	89	60600
HAE75-110S05W	43 ~ 160	5	15	10	91	30000
HAE75-110S12W	43 ~ 160	12	6.3	10	91	5250
HAE75-110S15W	43 ~ 160	15	5	10	91	3330
HAE75-110S24W	43 ~ 160	24	3.2	10	90	1330
HAE75-110S28W	43 ~ 160	28	2.7	10	90	960
HAE75-110S48W	43 ~ 160	48	1.6	10	90	330

## PART NUMBER STRUCTURE

Series Name	Input Voltage (VDC)	Output Quantity	Output Voltage (VDC)	Input Range	Ctrl and Pin Options	Through hole type <sup>(1)</sup>	Assembly Option
HAE75 - 48 S 05 W - P TH HS	24:9~36 48:18~75 110:43~160	S:Single	3P3:3.3 05:5 12:12 15:15 24:24 28:28 48:48	4:1	□:Negative logic, 0.200" pin length L:Negative logic, 0.145" pin length P:Positive logic, 0.200" pin length S:Positive logic, 0.145" pin length	□: Thread TH: No thread	□: None <b>Heat-sink type:</b> HS: Height H=0.45" vertical fin, 7G-0021A-F HS1: Height H=0.24" horizontal fin, 7G-0022A-F HS2: Height H=0.24" vertical fin, 7G-0023A-F HS3: Height H=0.45" horizontal fin, 7G-0024A-F <b>Terminal block type<sup>(2)</sup>:</b> T: Wall mounted TF: Wall mounted with EMC filter <sup>(3)</sup> TF1: Wall mounted with EMC filter can be connected to PE ⊕ <sup>(3)</sup>

(1) The module can't equip Heat-sink with TH option.

(2) Terminal block type only for 0.200" pin length.

(3) EMI filter meet EN55011, EN55022 Class A.

## INPUT SPECIFICATIONS

Parameter	Conditions		Min.	Typ.	Max.	Unit
Operating input voltage range	24Vin(nom)		9	24	36	VDC
	48Vin(nom)		18	48	75	
	110Vin(nom)		43	110	160	
Start up voltage	24Vin(nom)				9	VDC
	48Vin(nom)				18	
	110Vin(nom)				43	
Shutdown voltage	24Vin(nom)			7.5		VDC
	48Vin(nom)			16		
	110Vin(nom)			36		
Start up time	Constant resistive load	Power up	110Vin(nom)	60		ms
		Others	110Vin(nom)	25		
		Remote ON/OFF	110Vin(nom)	60		
		Others	110Vin(nom)	25		
Input surge voltage	1 second, max.	24Vin(nom)			50	VDC
		48Vin(nom)			100	
		110Vin(nom)			185	
Input filter <sup>(1)</sup>				Pi type		
Remote ON/OFF	Referred to -Vin pin	Negative logic (Standard)	DC-DC ON	Short or 0 ~ 1.2VDC		mA
			DC-DC OFF	Open or 3 ~ 12 VDC		
		Positive logic (Option)	DC-DC ON	Open or 3 ~ 12 VDC		
			DC-DC OFF	Short or 0 ~ 1.2VDC		
		Input current of Ctrl pin		-0.5		
Remote off input current			3			

## OUTPUT SPECIFICATIONS

Parameter	Conditions		Min.	Typ.	Max.	Unit
Voltage accuracy			-1.0		+1.0	%
Line regulation	Low Line to High Line at Full Load		-0.1		+0.1	%
Load regulation	No Load to Full Load		-0.1		+0.1	%
Voltage adjustability	Maximum output deviation is inclusive of remote sense		-20		+10	%
Remote sense	% of Vout(nom)				10	%
	If remote sense is not being used, Sense pins should be connected to corresponding polarity OUTPUT pins.					
Ripple and noise	Measured by 20MHz bandwidth					mVp-p
	With a 4.7μF/50V X7R MLCC	3.3Vout, 5Vout		75	100	
	With a 4.7μF/50V X7R MLCC	12Vout, 15Vout		100	125	
	With a 4.7μF/50V X7R MLCC	24Vout, 28Vout		200	250	
	With a 2.2μF/100V X7R MLCC	48Vout		300	350	
Temperature coefficient			-0.02		+0.02	%/°C
Transient response recovery time	25% load step change			200	250	μs
Over voltage protection	% of Vout(nom); Hiccup mode		115		130	%
Over load protection	% of Iout rated; Hiccup mode	110Vin(nom)		150		%
		Others	110		140	
Short circuit protection			Continuous, automatic recovery			

## GENERAL SPECIFICATIONS

Parameter	Conditions		Min.	Typ.	Max.	Unit
Isolation voltage	1 minute (Reinforced insulation)	110Vin(nom)	3000			VAC
	1 minute (Basic insulation)	Others	2250			VDC
Isolation resistance	500VDC		1			GΩ
Isolation capacitance					2500	pF
Switching frequency			270	300	330	kHz
Safety approvals			UL60950-1 EN60950-1 IEC60950-1			
Case material	24Vin(nom) and 48Vin(nom) 110Vin(nom)		Aluminum base-plate with plastic case			Metal
Base material	24Vin(nom) and 48Vin(nom)					FR4 PCB
Potting material						Silicone (UL94 V-0)
Weight	Module stand alone		97g (3.42oz)			
	HAE75-□□S□□W -T		200g (7.05oz)			
	HAE75-□□S□□W -TF		280g (9.88oz)			
	HAE75-□□S□□W -TF1		287g (10.12oz)			
MTBF	MIL-HDBK-217F, Full load					3.362x10 <sup>5</sup> hrs

**ENVIRONMENTAL SPECIFICATIONS**

Parameter	Conditions	Min.	Typ.	Max.	Unit
Operating case temperature	Base-plate	-40		+105	°C
Over temperature protection			+115		°C
Storage temperature range	Terminal block type Others	-40 -55		+105 +125	°C
Thermal impedance <sup>(2)</sup>	Vertical direction by natural convection (20LFM) Module without assembly option Heat-sink type with 0.24" Height Heat-sink type with 0.45" Height		6.7 5.4 4.7		°C/W
Thermal shock					MIL-STD-810F
Shock					EN61373, MIL-STD-810F
Vibration					EN61373, MIL-STD-810F
Relative humidity					5% to 95% RH

**EMC SPECIFICATIONS**

Parameter	Conditions	Level
EMI <sup>(3)</sup>	EN55011, EN55022	Class A Class B
ESD	EN61000-4-2 Air ±8kV and Contact ±6kV	Perf. Criteria A
Radiated immunity	EN61000-4-3 20V/m	Perf. Criteria A
Fast transient <sup>(4)</sup>	EN61000-4-4 ±2kV	Perf. Criteria A
Surge <sup>(4)</sup>	EN61000-4-5 EN55024 ±2kV and EN50155 ±2kV	Perf. Criteria A
Conducted immunity	EN61000-4-6 10Vr.m.s	Perf. Criteria A
Power frequency magnetic field	EN61000-4-8 100A/m continuous; 1000A/m 1 second	Perf. Criteria A

**Note:**

- Input source impedance: The power module will operate as specifications without external components, assuming that the source voltage has a very low impedance and reasonable input voltage regulation. Highly inductive source impedances can affect the stability of the power module. Since real-world voltage source has finite impedance, performance can be improved by adding external filter capacitor. The HAE75-24S□□W recommended 4.7μF/50V X7R MLCC or Nippon Chemi-con KY series, 68μF /100V or better capacitor.
- (1)Thermal test condition with vertical direction by natural convection (20LFM).  
(2)The heat-sink is optional and P/N: 7G-0021A-F , 7G-0022A-F , 7G-0023A-F , 7G-0024A-F. Please refer to heat-sink selection guide.
- The standard module meets EMI Class A or Class B with external components. For further information, please contact with P-DUKE.
- An external input filter capacitor is required if the module has to meet EN61000-4-4, EN61000-4-5.  
The HAE75-24S□□W and HAE75-48S□□W recommended 2 pcs of aluminum electrolytic capacitor (Nippon Chemi-con KY series, 220μF/100V) to connect in parallel.  
The HAE75-110S□□W recommended 2 pcs of aluminum electrolytic capacitor (Nippon Chemi-con KXJ series, 150μF/200V) to connect in parallel.
- CASE GROUNDING : Connecting four screw bolts to shield plane will help to reduce the EMI.
- For further information, please contact with P-DUKE.

**CAUTION:** This power module is not internally fused. An input line fuse must always be used.

**CHARACTERISTIC CURVE**

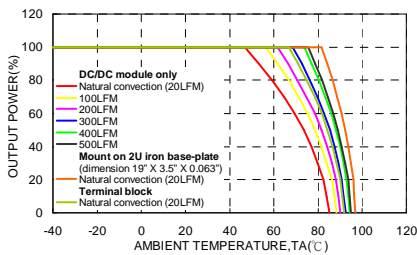

HAE75-48S05W Derating Curve (Note 2)

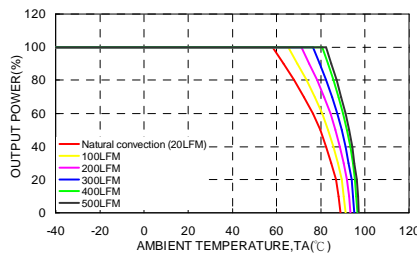

HAE75-48S05W Derating Curve (Note 2) With 0.24" Height Heat-sink

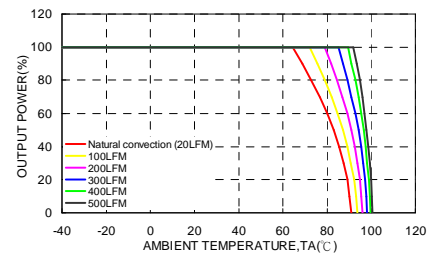

HAE75-48S05W Derating Curve (Note 2) With 0.45" Height Heat-sink

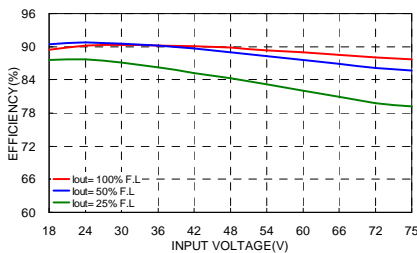

HAE75-48S05W Efficiency vs. Input Voltage

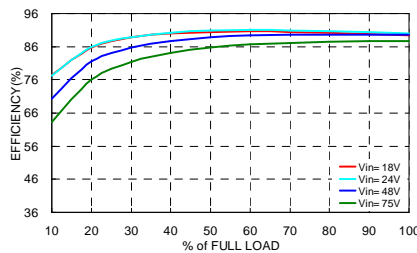

HAE75-48S05W Efficiency vs. Output Load

**MECHANICAL DRAWING**

HAE75-24S□□W, HAE75-48S□□W

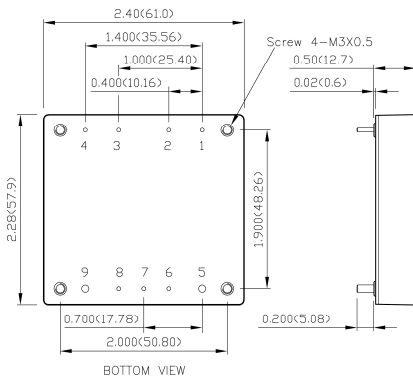

1. All dimensions in inch (mm)
2. Tolerance :x.xx±0.02 (x.x±0.5)  
x.xxx±0.01 (x.xx±0.25)
3. Pin pitch tolerance ±0.01 (0.25)
4. Pin dimension tolerance ±0.004(0.1)
5. Mounting screws should always be used.
6. The screw locked torque:  
MAX 5.0kgf-cm(0.49N-m)

**PIN CONNECTION**

PIN	DEFINE	DIAMETER
1	-Vin	0.04 Inch
2	Case	0.04 Inch
3	Ctrl	0.04 Inch
4	+Vin	0.04 Inch
5	-Vout	0.08 Inch
6	-Sense	0.04 Inch
7	Trim	0.04 Inch
8	+Sense	0.04 Inch
9	+Vout	0.08 Inch

**EXTERNAL OUTPUT TRIMMING**

Output can be externally trimmed by using the method shown below.

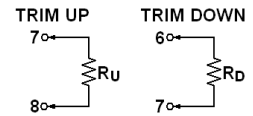

$$R_U = \left( \frac{V_{OUT} (100 + \Delta\%)}{1.225 \Delta\%} - \frac{(100 + 2\Delta\%)}{\Delta\%} \right) k\Omega$$

$$R_D = \left( \frac{100}{\Delta\%} - 2 \right) k\Omega$$

HAE75-110S□□W

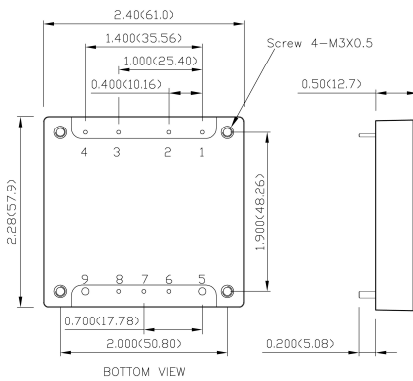

1. All dimensions in inch (mm)
2. Tolerance :x.xx±0.02 (x.x±0.5)  
x.xxx±0.01 (x.xx±0.25)
3. Pin pitch tolerance ±0.01 (0.25)
4. Pin dimension tolerance ±0.004(0.1)
5. Mounting screws should always be used.
6. The screw locked torque:  
MAX 3.5kgf-cm(0.34N-m)

**HEAT-SINK TYPE OPTIONS**

Vertical Fin Orientation, Suffix:-HS, -HS2

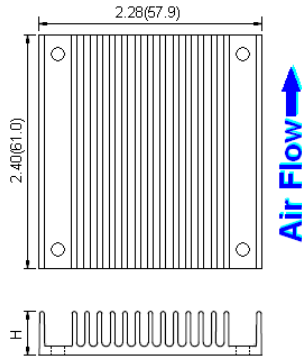

Horizontal Fin Orientation, Suffix:-HS1, -HS3

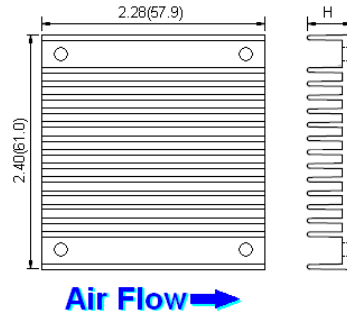

<b>HS:</b>	Height H=0.45" vertical fin, 7G-0021A-F
<b>HS1:</b>	Height H=0.24" horizontal fin, 7G-0022A-F
<b>HS2:</b>	Height H=0.24" vertical fin, 7G-0023A-F
<b>HS3:</b>	Height H=0.45" horizontal fin, 7G-0024A-F

1. All dimensions in inch (mm)
2. Tolerance :x.xx±0.02 (x.x±0.5)  
x.xxx±0.01 (x.xx±0.25)

**TERMINAL BLOCK TYPE OPTION**

HAE75-□□S□□W -T

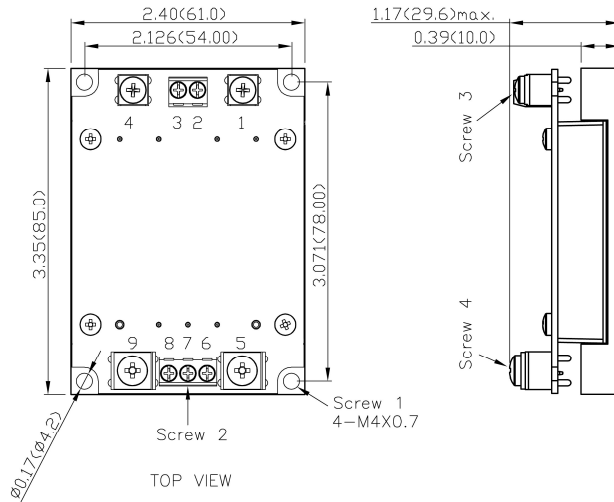

**TERMINAL CONNECTION : -T,-TF**

NO.	DEFINE
1	-Vin
2	Case
3	Ctrl
4	+Vin
5	-Vout
6	-Sense
7	Trim
8	+Sense
9	+Vout

**EXTERNAL OUTPUT TRIMMING**

Output can be externally trimmed by using the method shown below.

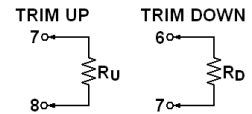

$$R_U = \left( \frac{V_{OUT} (100 + \Delta\%)}{1.225 \Delta\%} - \frac{(100 + 2\Delta\%)}{\Delta\%} \right) k\Omega$$

$$R_D = \left( \frac{100}{\Delta\%} - 2 \right) k\Omega$$

- All dimensions in inch (mm)
- Tolerance : x.xx±0.02 (x.x±0.5)  
x.xxx±0.01 (x.xx±0.25)
- Screw 1 locked torque:  
MAX 11.2kgf-cm/ 1.10N-m
- Screw 2 locked torque:  
MAX 5.2kgf-cm/ 0.51N-m
- Screw 3, 4 locked torque:  
MAX 12.0kgf-cm/ 1.18N-m

HAE75-□□S□□W -TF

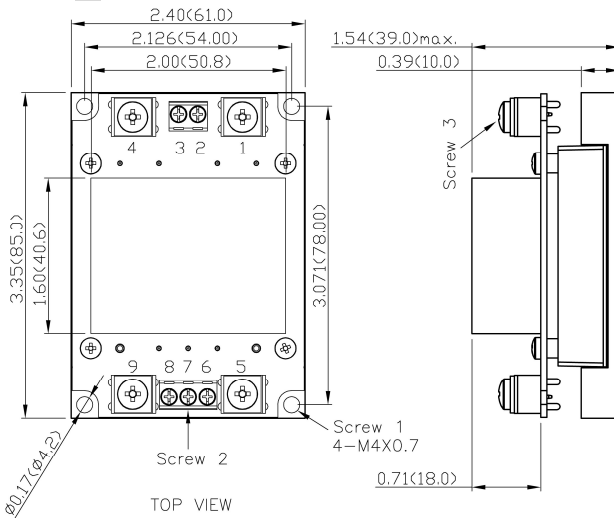

HAE75-□□S□□W -TF1

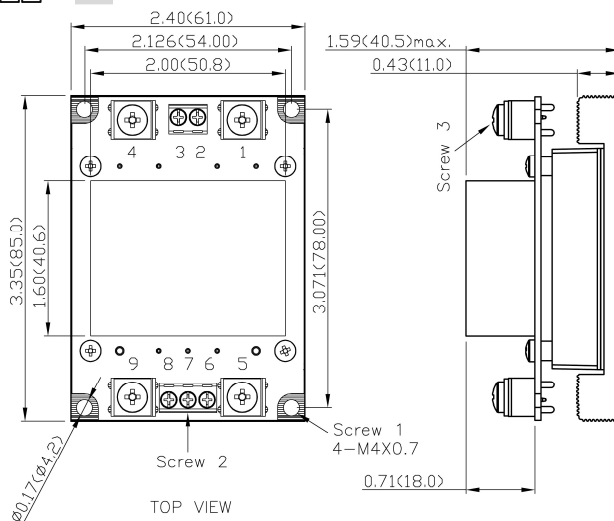

**TERMINAL CONNECTION : -TF1**

NO.	DEFINE
1	-Vin
2	NC
3	Ctrl
4	+Vin
5	-Vout
6	-Sense
7	Trim
8	+Sense
9	+Vout